

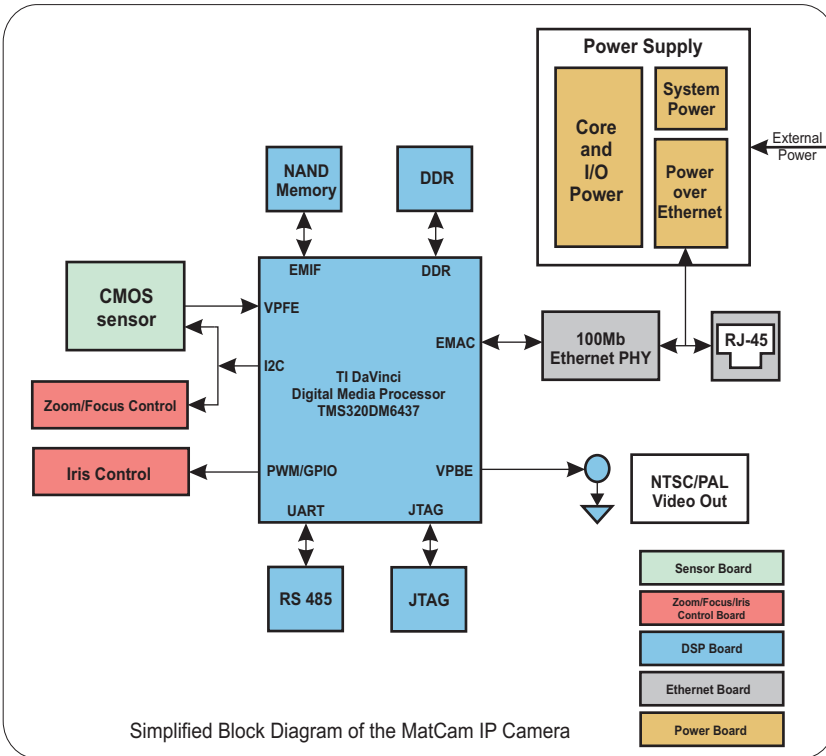

RT-CAM300 MATCAM - IP CAMERA

The MatCam is self-contained programmable, intelligent camera unit capable of processing acquired images according to client requirements to extract relevant data. These data can then be passed to external systems via network interface.

The unique feature of the MatCam is programmability: image processing and image analysis algorithms can be specified by the user via MathWorks Simulink[®] block diagram which is used for code generation. This approach enables developer to check new video algorithms in short time, minimizing the cost of development cycle.



FEATURES

- Based on TI TMS320DM6437 DaVinci™ Digital Media Processor
- Aptina's 5Mp CMOS sensor
- Highest resolution 2592x1944
- System: PAL/NTSC
- Supports PoE on CAT-5 cable, according to IEEE 802.3af
- Motorized zoom, focus and iris can be controlled
- CS Lens mount or C mount with C/CS adapter
- Power requirement : DC 12V / PoE
- Dimensions w/o lens (WxHxD): ~70x60x150 mm

CONNECTORS

- Supports 100 Mb Ethernet Network connector
- Supports RS-485 interface
- Supports motorized DC lens Iris control 4-pin EIAJ connector
- Circular connector for support of motorized DC lens Zoom/Focus control available
- Development system connector (JTAG) is available
- Video output: Composite



MatCam rear view

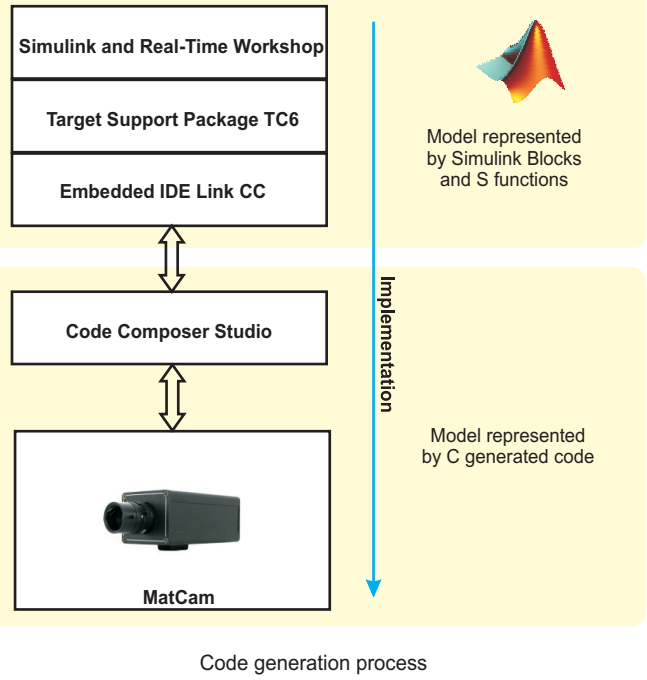

APPLICATION

- Image processing/analysis algorithm can be specified by the user via Simulink® block diagram
- Simulink® block for CMOS sensor control available
- Simulink® block for TI interface for video processing control available
- Simulink® block for optical front end (zoom/focus/iris) control available
- H264 encoder block is under development

All information and data contained in this product information are without any commitment, are not to be considered as an offer for conclusion of a contract, nor shall they be construed as to create any liability. Product or development sample availability and delivery are exclusively subject to our respective order confirmation form. By this publication, RT-RK does not assume responsibility for patent infringements or other rights of third parties which may result from its use. No part of this publication may be reproduced, photocopied, stored on a retrieval system, or transmitted without the express written consent of RT-RK.