

Customer

The customer is a world known international company playing significant role in various fields of consumer electronic market. Besides audio integrated circuits (ICs), their product portfolio comprises of numerous analog and digital TV video integrated circuits.

Project Overview

The goal of the project was a development of prototyping environment for next generation of audio system IC for TV and audio device market. Prototyping environment was used for two main purposes: as concept verification environment and as pre-silicon SW development environment. The first request was dictated by need to verify new IP blocks as much as close to real application, before concept freeze. Later was dictated by statement that long design cycle is no longer acceptable in the presence of shorter Time-to-Market pressures for products with increasingly shorter market windows.

Field Programmable Gate Array (FPGA) technology, powered with advanced simulation and synthesis tools is becoming the most preferred platform for the rapid prototyping of integrated digital systems. Due to its nature, FPGA internally is capable to support prototyping of pure digital designs, but it also provides connectivity to real (usually analog) world.

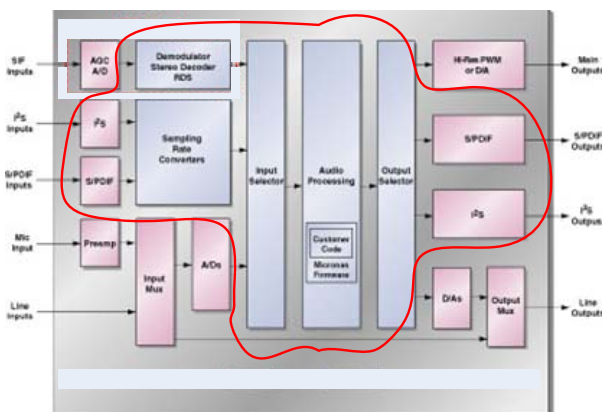

Multi channel audio IC architecture
(FPGA design architecture circled)

The project deals with customization of ASIC RTL code (under development) for FPGA platform and as well as design of interface boards for connection of FPGA design to real world.

The initial prototyping concept was developed in a joint action with concept, HW and SW design engineers. Critical

points in design were identified in order to provide optimal FPGA design.

Main challenges during development were:

- customization of ASIC RTL code while it is still under development
- design of FPGA specific workarounds for ASIC specific RTL modules (memories, PLLs, pads, clocks, ...)
- designing platform extension board
- endeavor to do all previous listed and keep design as fast as possible, e.g. more close to ASIC speed

The project started four weeks after ASIC RTL design was kicked off and last all the way until 1st silicon was brought up on the evaluation board. Development in such "ever-changing ASIC RTL code" environment required great team flexibility and short turnover time between new ASIC RTL code release and FPGA RTL code release.

FPGA development process comprised of two major parts:

- Functional co-verification of ASIC and FPGA RTL codes.
- Synthesis of FPGA RTL code for specific prototyping platform

Functional co-verification was done using Cadence Incisive simulation SW and Novas Debussy code level debugger.

Synthesis was performed with Synopsys Synplify Pro, ProDesign Chipit Manager and Xilinx XST SW, all for prototyping platform ProDesign CHIPit Gold.

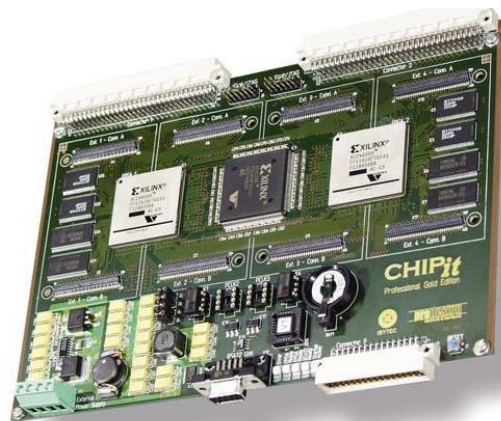

Photo of prototyping platform

The developed prototyping environment is able to provide "near ASIC" functionality, easy multi audio processing DSP SW development and RTL code debugging, as well as versatile interfaces. Interfaces on extension board provide window from FPGA digital design into multiple analog audio line in and out (ADCs, DACs), digital audio in and out (I2S

RT-RK Computer Based Systems LLC

Dr Ilije Djuricica 2
21000 Novi Sad
Serbia

phone: +381 (0)21 4801 100
fax: +381 (0)21 450 721
e-mail: info@rt-rk.com
web: www.rt-rk.com

and S/PDIF), communication (I2C, SPI) and peripheral world (LEDs, switches and push-buttons).

The development lasted six months. It involved two FPGA design engineers, one hardware engineer for schematics and PCB design and one engineer for DSP software support for FPGA design bring up, as well as one project manager.

Benefits

The project covered the complete development from the prototyping environment idea until HW/SW prototyping platform. All development steps were either conducted or organized by RT-RK, in correspondence with the customer. The final solution fulfills the customer requirements in terms of performances. The complete development process and costs were transparent to the customer via regular meetings and appropriate reports.

Prototyping Environment Gallery



Photo of prototyping environment for multi channel audio IC

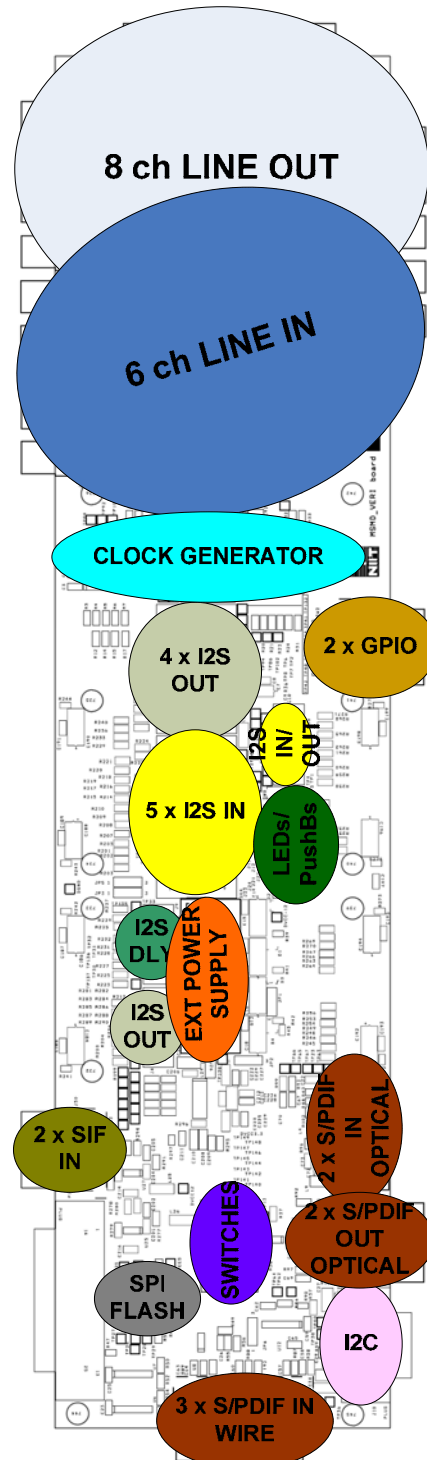

Extension board PCB sections

RT-RK Computer Based Systems LLC

Dr Ilije Djuricica 2
21000 Novi Sad
Serbia

phone: +381 (0)21 4801 100
fax: +381 (0)21 450 721
e-mail: info@rt-rk.com
web: www.rt-rk.com